



18KW Multifunction Heat Pump with Scroll Compressor for Hot Water and Room Heating Cooling

Our Product Introduction

Basic Information

- Place of Origin: China
- Brand Name: meidibao
- Certification: CE
- Model Number: KFXKS-18I-M1
- Minimum Order Quantity: 3 units
- Price: negotiate a price
- Packaging Details: Factory standard packing
- Delivery Time: 25-30 days
- Payment Terms: T/T
- Supply Ability: 5 units one day



Product Specification

- Heat Exchanger: Plate Heat Exchanger Or Shell In Coil
- Power Supply: 380V/3PH /60Hz Or 50Hz
- Compressor Type: Scroll
- Type: Multifunction
- Use: Hot Water + Room Heating+cooling
- Cooling: 10.6KW
- Name: Custom Heat Pump
- Highlight: **Multifunction Custom Heat Pump,
18KW Custom Heat Pump,
18KW Hot Water Heat Pump**

for more products please visit us on air-source-heatingpump.com

Multifunction 18KW Custom Heat Pump - Hot Water + Room Heating/Cooling

The Multifunction 18KW Custom Heat Pump provides comprehensive climate control solutions with versatile operation modes for both domestic hot water and room temperature management.

Function Modes

- Single hot water mode
- Single air-conditioning mode
- Single heating mode
- Hot water + air-conditioning mode
- Hot water + heating mode

Key Features

- High power output to meet large-scale heating and cooling demands
- Famous brand compressor for reliable performance
- Multi-purpose design - one machine achieves air-conditioning, domestic hot water, and house heating
- Comprehensive multiple protection systems

Technical Specifications

Product	Multifunction Air Source Heat Pump
Model	KFXKS-18I-M1
Climatic Type	Normal
Power Supply	380V /60Hz
Rated Heating Capacity	18.5kW
Rated Power Input	4.86kW
Rated Cooling Capacity	10.6KW
Rated Cooling Power	4.07KW
Max Rated Current	28.6A
Refrigerant	R410A/4000
Working Temperature	-7-43
Water Pipe Size	DN25
Noise Level	≤65dB(A)
Product Dimension	750×690×1060mm
Net Weight	154kg

Heating test conditions: ambient Dry/Wet Bulb Temp: 20 / 15 ; Water Inlet Outlet Temp: 15 / 55

Cooling test conditions: ambient Dry/Wet Bulb Temp: 35 / 24 ; Water Inlet Outlet Temp: 12 / 7

Company Advantages

Meidibao maintains a strong R&D center and production line, specializing in manufacturing and supplying air source heat pumps, water/ground source heat pumps, and related heat pump products. With dedicated professional teams in engineering, production, management, and marketing, we provide comprehensive services from project consultation and product design to sampling, production, quality control, technical support, and after-sales service.

Plate Heat Exchanger

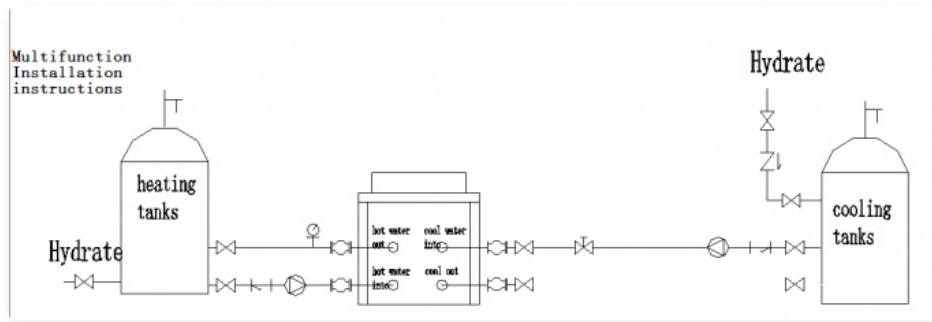

Meidibao® Foshan Meidebao Intelligent Electrical Appliances Co., Ltd

☎ 8613534489875

✉ info@meidibao.com

🌐 aresource-heatingpump.com

No9, Guangming North Road, Jiangyi, Leliu Town, Shunde District, Foshan City Guangdong Province, China