



200L / 250L Capacity All-In-One Heat Pump with R290 Refrigerant and WiFi Enabled for Custom Installation

Our Product Introduction

Basic Information

- Place of Origin: China
- Brand Name: Meidibao
- Certification: CE
- Model Number: Top Portion of All-In-One
- Minimum Order Quantity: Order 200 units after proofing
- Price: For discussion
- Packaging Details: Factory standards
- Delivery Time: 15~20 days
- Payment Terms: T/T
- Supply Ability: 400 units per Month



Product Specification

- Capacity: 200L / 250L
- Evaporator Color: Blue
- Energy Efficiency Class: I
- Refrigerant: R290
- Heating: 3.5KW
- Voltage: 1/220V/50HZ
- Name: Custom Heat Pump
- Highlight: **250L All In One Heat Pump,
All In One R290 Heat Pump,
All In One Heat Pump R290**

for more products please visit us on airsource-heatingpump.com

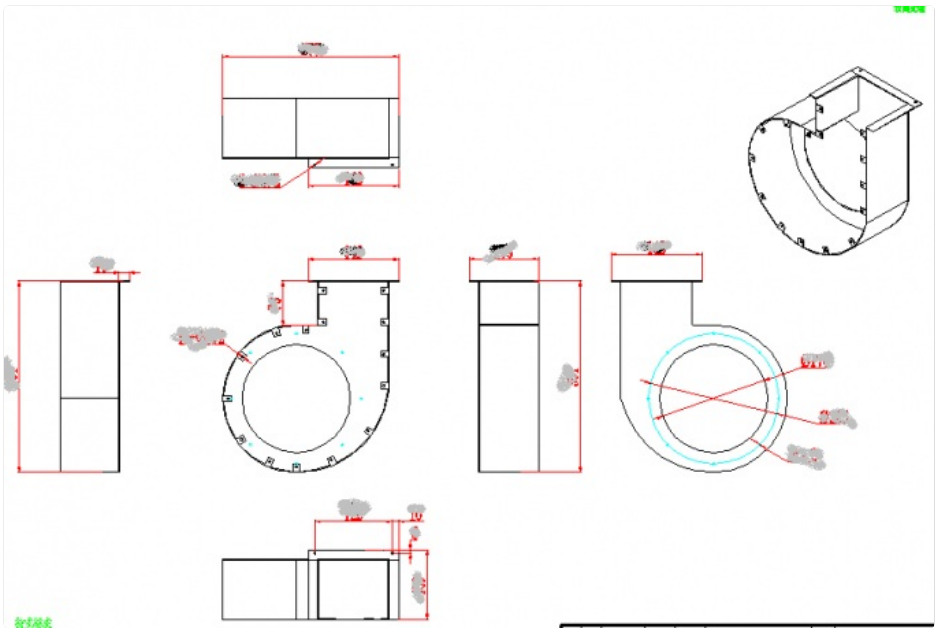
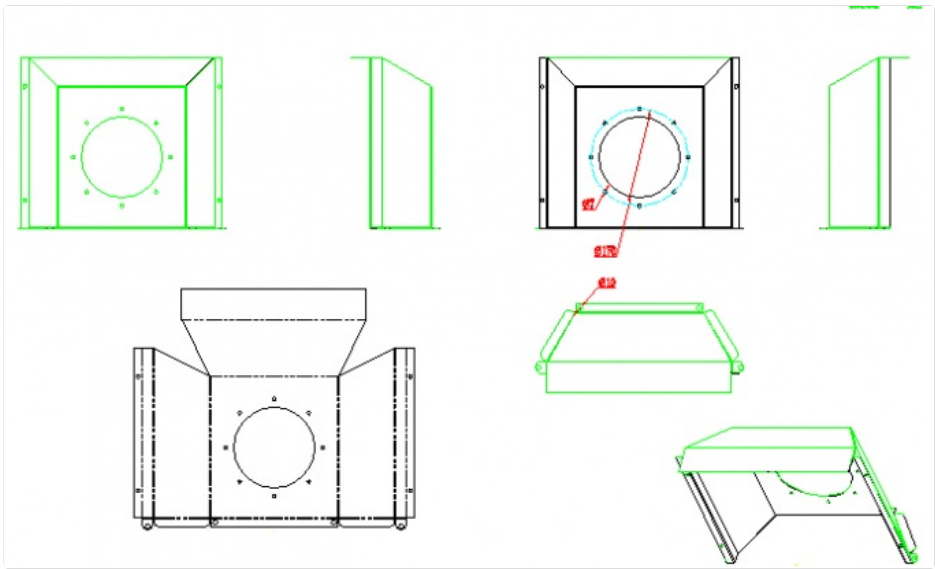

Manufacturing & Installation Process

Made in Chinese factories





Loading containers



Customers add water tanks locally



Final installation ready





Meidibao[®] Foshan Meidebao Intelligent Electrical Appliances Co., Ltd

☎ 8613534489875

✉ info@meidibao.com

🌐 airsource-heatingpump.com

No9, Guangming North Road, Jiangyi, Leliu Town, Shunde District, Foshan City Guangdong Province, China