



KFXKS-74II-M1 74KW Multifunction Air Source Heat Pump with Scroll Compressor for Custom Heating and Cooling Solutions

Our Product Introduction

Basic Information

- Place of Origin: China
- Brand Name: meidibao
- Certification: CE
- Model Number: KFXKS-74II-M1
- Minimum Order Quantity: 1 units
- Price: negotiate a price
- Packaging Details: Factory standard packing
- Delivery Time: 25-30 days
- Payment Terms: T/T
- Supply Ability: 5 units one day



Product Specification

- Rated Heating Capacity: 74kw
- Color: Galvanized
- Heat Exchanger: Shell In Coil
- Power Supply: 380V/3PH /60Hz Or 50Hz
- Compressor Type: Scroll
- Type: Multifunction
- Highlight: **74KW Custom Heat Pumps,
Versatile Solution Custom Heat Pumps,
Multifunction Custom Heat Pumps**

for more products please visit us on airsource-heatingpump.com

Product Description

KFXKS-74II-M1 Multifunction Custom Heat Pumps 74KW Powerfun And Versatile Solution

Product Overview

The **KFXKS-74II-M1 Multifunction Custom Heat Pump** is a high-performance, customizable solution designed to meet specific heating, cooling, and hot water needs. With an impressive 74 kW capacity, this model efficiently serves a variety of applications, from residential complexes to commercial facilities.

Key Features

- Powerful Heating Capacity:** Delivers up to 74 kW, ideal for large spaces or high-demand applications
- Multi-Functionality:** Capable of heating, cooling, and providing hot water, making it versatile and cost-effective
- Customizable Design:** Tailored to meet your unique requirements, including operational settings and specific energy configurations
- Energy-Efficient:** Utilizes advanced technology to reduce energy consumption while maintaining optimal performance
- Durability & Reliability:** Built with high-quality materials for long-lasting use and dependable operation in diverse environments

Technical Specifications

Product	Multifunction Custom Heat Pump
Model	KFXKS-74II-M1
Climatic type	Normal
Power supply	380V /60Hz
Rated heating capacity	74kW
Rated power input	19.47kW
Rated cooling capacity	40KW
Rated cooling power	20KW
Max Rated current	45.9A
Refrigerant	R410A/2800g*4
Working temperature	-7-43
Water pipe size	DN65
Noise	≤72dB(A)
Product dimension	2000*1100*1960mm
Net weight	580kg

Heating test conditions: ambient Dry/Wet Bulb Temp: 20 / 15 ; Water Inlet Outlet Temp: 15 / 55

Cooling test conditions: ambient Dry/Wet Bulb Temp: 35 / 24 ; Water Inlet Outlet Temp: 12 / 7

Company Advantages

With a strong R&D center and production line, we are constantly specialized in producing and supplying air source heat pump, water/ground source heat pump and related heat pump products

With dedicated professional members in engineering, production, management and marketing team, we provide comprehensive support from project consultation to after-sales service

Our service covers project consultation, product design, sampling, production, quality control, technical support, and after-sales service

Plate Heat Exchanger

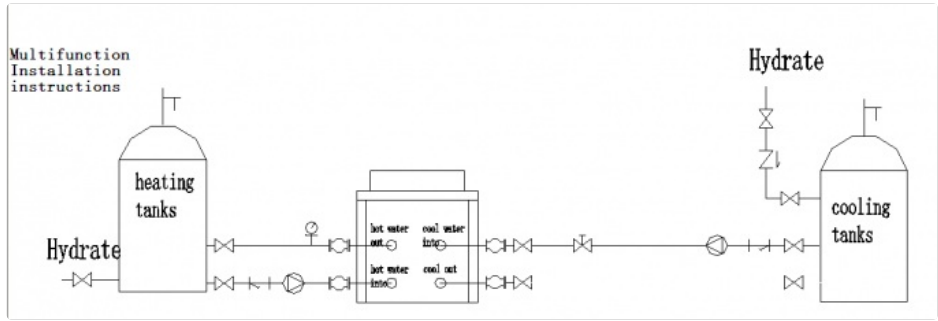



Meidibao[®] Foshan Meidebao Intelligent Electrical Appliances Co., Ltd

☎ 8613534489875

✉ info@meidibao.com

🌐 airsource-heatingpump.com

No9, Guangming North Road, Jiangyi, Leliu Town, Shunde District, Foshan City Guangdong Province, China